

Horizontal Form-Fill & Seal Ice Bagger



High-speed roll-stock bagging machine designed specifically for the needs of the Packaged Ice industry.

- 2112i model for small to medium consumer bag sizes (typically 5-10lb bags)
- 3118i model for small consumer to larger bulk product (typically 5-40lb bags)
- Fully automatic control of bagger, upstream feed, and downstream bag transition to JMC IB-1008S ice baler or JMC Robot Palletizer
- Fast product change-over with easily accessible and maintenance friendly heat seal tooling
- Robust, modern PLC control system with remote troubleshooting access
- Production data recording



Wicketed Baggers



Robotic Palletizers



Hot Air Sealers



Master Balers

Horizontal Form-Fill & Seal Ice Bagger

HFFS-3118i

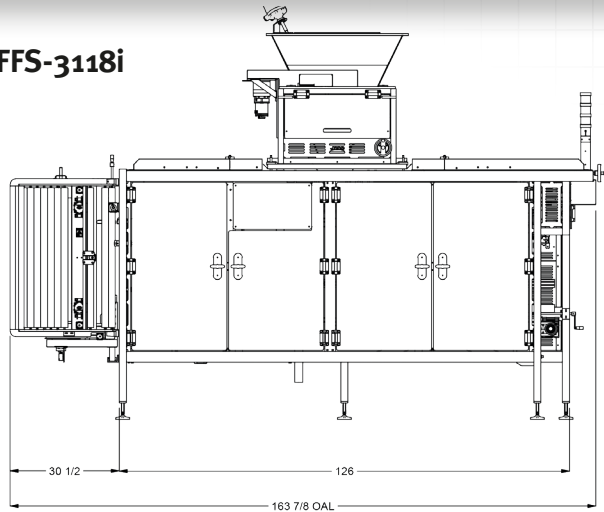

HFFS-2112i

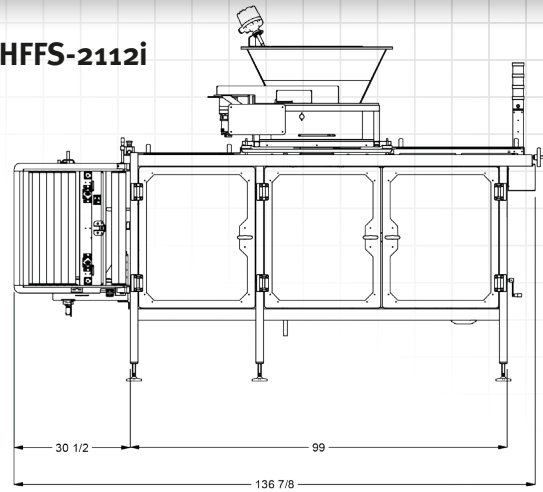

STANDARD FEATURES

- Omron PLC with standard 7" touch screen operator interface
- Full Stainless Steel and FDA approved materials/contact surfaces. Improved hygienic design for food safety and easy cleaning
- Servo controlled axes for repeatable and efficient high-performance motion
- Servo powered side heat seal assembly (no burning, no fumes)
- Servo powered top heat seal assembly
- Designed to handle wet and cold environments
- Machine indexes product bags from std registration marks or from clear film with no markings based on desired bag width
- 'Cup-style' rotary volumetric filler for higher throughput and better accuracy. Conventional drum volumetric available for height restricted applications
- Vibrating infeed chutes to improve product flow
- Pneumatic core chuck for positive gripping of the film roll
- Adjustable bag top release for consistent product discharge onto downstream equipment

COMPLIMENTARY PRODUCTS

- JMC IB-1008S - Ice Baler
- JMC Robot Palletizer (Conveyors, Pallet Distribution, Robot Tooling, Stretch Wrapping etc.)
- JMC BB-1640 - Bulk Bagger (Wicketed Bags)
- JMC Fuse Aire 4 - Hot Air Sealer
- JMC Conveyor Systems w/ Optional Metal Detection

OPTIONAL FEATURES

- Gusset Former
- Larger HMI options (9", 12", 15" available)
- Inkjet Printer Package
- Scrap trim transfer options
- Mobility Kit

SPECIFICATIONS

- Power Drop: 208-Y120V / 3Ph / 60Hz
3118i @ 40A, 2112i @ 30A
- Air: 15cfm @ 90 PSig clean & dry
- Machine Weight: 3118i @ 2,700lbs, 2112i @ 2,100lbs

Manufactured for the world market by:



JMC AUTOMATION IN PACKAGING

3470 Mainway
Burlington, Ontario, Canada L7M 1A8
Toll-free: 1-800-263-5252
If busy, call: (905) 335-4196
Website: www.jmcpackaging.com
E-mail: sales@jmcpackaging.com

Represented By: